

Electro-Hydraulic, Aeroload Simulation (ALS) Systems

The ALS — sometimes referred to as a fin loader — is a general-purpose test instrument that can produce a wide range of rotary position motion, and/or active dynamic torque, to simulate loads that control surfaces experience during missile flight. Many customers use this equipment in conjunction with a multi-axis Flight Motion Simulator, to complete a hardware test suite for their guidance system article(s).

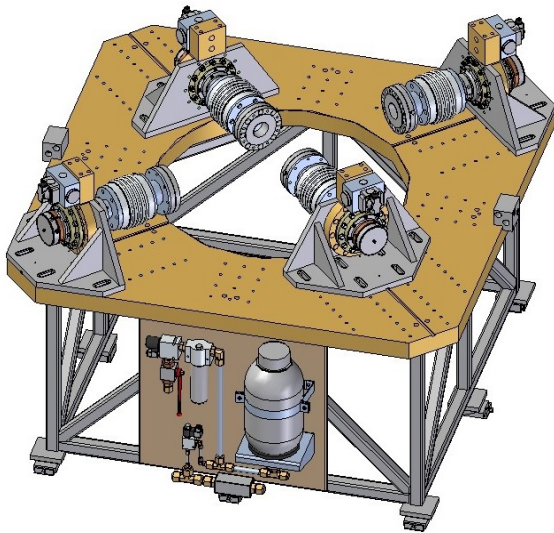

- Available in vertical (as shown) or horizontal axis body orientation, and with single- or multi-axis actuators.
- Modular construction, including System Control Console and Hydraulic Power Unit.
- Actuators and torque transducers custom-matched to application requirements.
- Rigid structure ensures operational fidelity.
- Direct closed-loop control of position, torque, and “spring” modes of operation. Includes “cage” mode (smooth position-to-torque mode transition) for initialization.
- Hydraulic snubbing, along with electronic and mechanical limits, address payload, system, and personnel safety.

Main configurable performance parameters, dependent on payload and application requirements:

Angular Displacement, degrees	Up to ± 55
Peak Velocity, degrees/sec	300 to 600
Peak Torque, in-lb	2000 to 12,000
Torque accuracy	0.1% of full-scale
Position Accuracy, degrees (feedback transducer-dependent)	± 0.05 to ± 0.003
Torque mode frequency response, Hz, typical (90° phase-lag, locked-rotor)	100 (150 for special applications)

Standard features:

- Torque-stiff flexible couplings allow actuator misalignments of up to 0.5° from orthogonal.
- Actuator mounting plate includes large clearance hole, and features to adjust actuators to match test article diameter.

Submit your requirements and let our engineers work with you toward an effective solution.

Rev B